

GAS EXPANSION THERMOMETER

Remote Panel Mounted with U-bracket Type

223 SERIES

**SENSE
TEC**

APPLICATIONS

Expansion thermometers can be installed in or mounted at nearly all locations. Versions with capillaries are used in locations which are not easily accessible and where long distances have to be bridged.

SPECIFICATIONS

| | | |
|---------------------------|---|-----------------------------|
| Nominal Dial Size | Ø2½"(63mm) ; Ø3"(75mm) ; Ø4"(100mm) ; Ø5"(125mm) ; Ø6"(150mm) | |
| Connection | Thread size: 1/4" ; 3/8" ; 1/2" ; 3/4" PT / NPT / PF(G,BSPP) Others available upon order Type: Rotary male thread with thread adapter (standard) Rotary female nut Compression fitting (sliding on probe) | |
| Case | Stainless Steel 304, IP65 | |
| Window | Glass | |
| Pointer and Dial | Aluminum | |
| Capillary | Stainless steel 304 length 0.5~20 meters available | |
| Probe Material | Stainless Steel 304 ; Stainless Steel 316 | |
| Probe Size | O.D.Ø6 / 6.35mm | Min. insertion length 100mm |
| | O.D.Ø8mm | Min. insertion length 75mm |
| | O.D.Ø9.5 / 10mm | Min. insertion length 60mm |
| | O.D.Ø12mm | Min. insertion length 50mm |
| Accuracy | ±1 division | |
| Optional accessory | Thermowell Electrical contacts | |



| Dial | A | B | C | D | E | F | d |
|------|-----|-----|-----|-----|----|-------------------|------|
| 2½" | 55 | 64 | 88 | 63 | 16 | 40 | 6 |
| 3" | 70 | 85 | 102 | 76 | 16 | 47 | 6.35 |
| 4" | 102 | 119 | 137 | 108 | 22 | 48 ⁽¹⁾ | 8 |
| 5" | 110 | 127 | 145 | 117 | 18 | 51 | 9.5 |
| 6" | 140 | 160 | 191 | 148 | 18 | 47 ⁽²⁾ | 10 |
| | | | | | | | 12 |

- (1) If switch contact is installed, F = 80mm
 (2) If switch contact is installed, the lens is acrylic and the lens height is 26mm (single contact) / 40mm (double contact)

Unit: mm

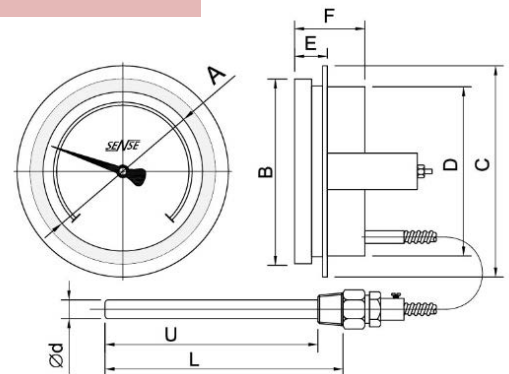

HOW TO ORDER

| | | | | | | | | | |
|-------|-------------|-------|-------------------|-------|-------------------------|---|--|-------------|---------------------------|
| 223 - | Dial | - | Range (°C) | - | Capillary length | - | Standard Connection | - | Probe |
| | | | | | | | Rotary male thread with thread adapter | | |
| | 25 | 2½" | -50/50 | 0/200 | (fill in size) | | Size | Type | Shape |
| | 30 | 3" | -10/50 | 0/250 | Meters | | 2 | 1/4" | P PT M Male |
| | 40 | 4" | 0/50 | 0/300 | | | 3 | 3/8" | N NPT F female |
| | 50 | 5" | 0/100 | 0/400 | | | 4 | 1/2" | F PF |
| 60 | 6" | 0/120 | 0/500 | | | 6 | 3/4" | M MM | |
| | | 0/150 | 0/600 | | | X | other | X other | |
| | | | | | | O | without connection | | |
| | | | | | | | | | Length |
| | | | | | | | | | U _____ |
| | | | | | | | | | L _____ |
| | | | | | | | | | fill in size after U or L |
| | | | | | | | | | Dia. |
| | | | | | | | | | d6 |
| | | | | | | | | | d6.35 |
| | | | | | | | | | d8 |
| | | | | | | | | | d9.5 |
| | | | | | | | | | d10 |
| | | | | | | | | | d12 |
| | | | | | | | | | Material |
| | | | | | | | | | SS304 |
| | | | | | | | | | SS316 |

Note if require other connection type

Example: 223-40-0/300-3M-4PM-U100mm-d12-SS304